

# HL-SD01

ORIGINALITY DESIGN SMART - AND BEAUTIFUL



**DOOR BELL**

CE FC 

## QUICK GUIDE

[www.thehonorlink.com](http://www.thehonorlink.com)

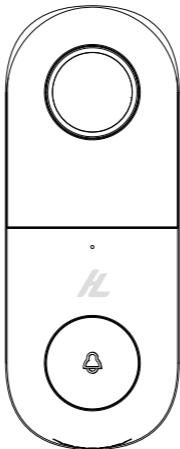

# What's in the box

Please consult this checklist for all parts.



HL-SD01



Angle Wall Mount



Pin



Screwdriver



Screw (4 kinds)

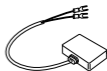

Chime Kit



Manual



3M

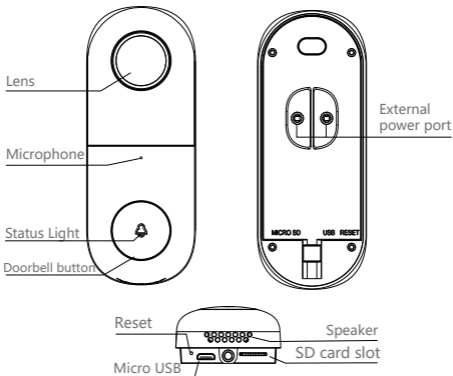

Power Port AC 12~24V

Doorbell button Press the button to activate the doorbell

Status light

- Solid red light on: network is malfunctional
- Blinking red light: wait for network connection (quickly blinking)
- Solid blue light on: the camera is working correctly

Microphone Capture sound for your video

SD card slot Support local SD Card storage (Max. 128GB)

Reset Press and hold on for 5 seconds with pin to reset the doorbell

- Step 1** First turn off the power breaker at your fuse box for your existing doorbell and mechanical chime. Ring your doorbell again to confirm it is now off.

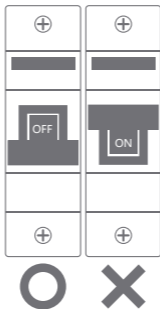

- Step 2** Find your mechanical chime that is a rectangular box, produces the sound when your doorbell is pressed. It may (or may not) be mounted immediately inside your FRONT door. And remove the cover.

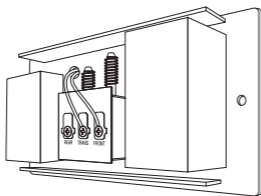

(Example of a Mechanical Chime)

- Step 3** Slightly unscrew both screw terminals and one hook from the Chime Kit under each screw (It does not matter which color wire from the Chime Kit connects to which screw).

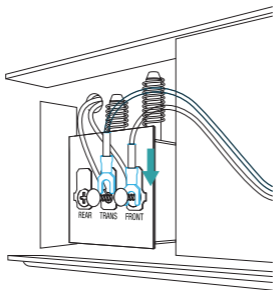

Locate the Chime Kit included in the smart doorbell's packaging, and the terminals on the inside of the chime. Connect one of the Chime Kit's prongs to the transformer terminal (usually labeled TRANS, T, AC, or 0). Connect the other prong to the chime's front terminal (usually labeled FRONT, F1, or C1). Either prong on the Chime Kit can be connected to either of the terminals on the chime.

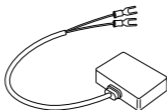

- Step 4** Using the included doubles sided tape, affix the Chime Kit to your chime wherever there is space and replace the cover. Be careful not to interfere with any of the chime's moving parts.

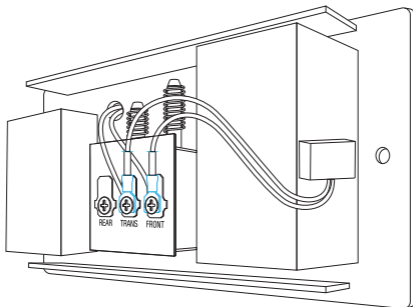

Ensure that the Chime Kit and wires **DO NOT** interfere with the mechanical parts of the chime. Mount on the outside of the chime if there is not enough room to mount inside. And replace your chime's cover.

## Mode 1 Doorbell General Installation

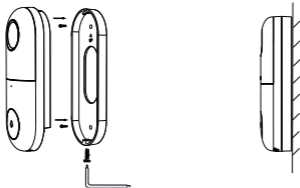

1. Fix the bracket to the wall with the mounting screws
2. Install the camera in the bracket and lock it with the screw

## Mode 2 Angle Wall Mount + Bracket + Doorbell Installation

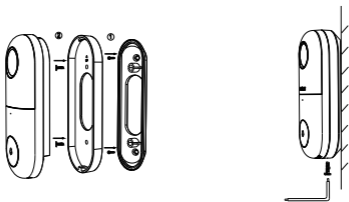

1. Fix the angle wall mount to the wall
2. Fix the mounting bracket in the angle wall mount
3. Install the camera in the bracket and lock it with the screw



Turn the doorbell power back on at the fuse box. The light on the doorbell button should turn on and after a few minutes become red slowly.

---

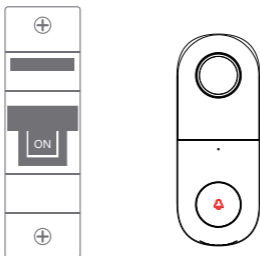



## Download

Honorlink Smart is available for both iOS and Android OS. Search the name 'Honorlink Smart', 'Honorlink Smart' in App Store or Google Play, or scan the QR-Code to download the App. You can select the App according to needs.

## Support



## Set up router

The router supports the 2.4GHz WiFi (doesn't support the 5GHz), and is connected to the WiFi network. Please set the parameters of the router before connecting the WiFi network, and record the SSID and password of your WiFi.



## Registration process

- Step 1 Open the Honorlink Smart App, click "Sign Up", read the "User Agreement Privacy Policy" and click "Agree".

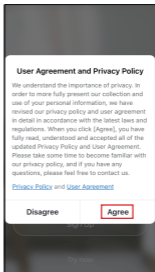
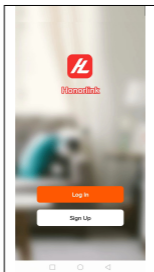

- Step 2 Input a legal and valid Mobile number or Email address and click "Get Verification Code". Input the verification code to log in.

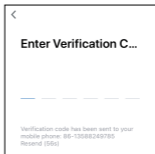
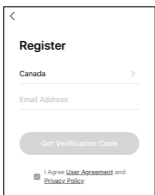



- 3 Power on and reset camera until the status indicator is flashing quickly or a prompt tone is heard, and then click "Next". Then input your WiFi's passwords and click "Next". Click "⇌" to change network.

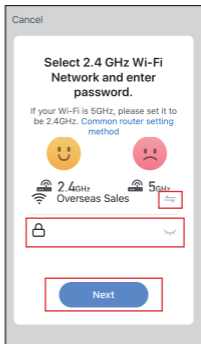
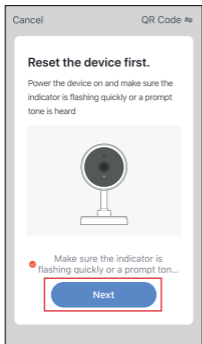

## Note:

- 1) Camera only supports 2.4GHz WiFi network.
- 2) The number of bits in the SSID and passwords of the router should not exceed 24 digits.

- 4 In this interface, you should scan the QR code in your phone with the camera, when the camera comes out "dong dong dong". And you can complete the configuration about 30s.

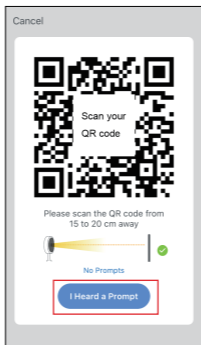

- 5 When connecting, you should make sure your router, mobile, and camera are as close as possible. When camera added successfully, click "Done" you could also DIY the camera's name.

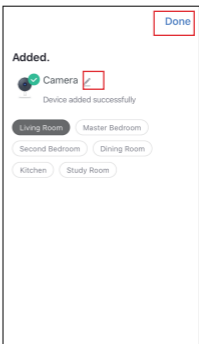
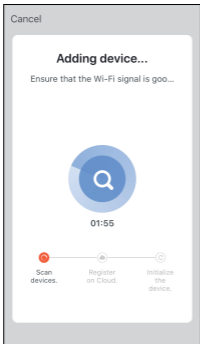

In "Smart Camera" interface,click "[edit icon]",you can set the camera common functions.

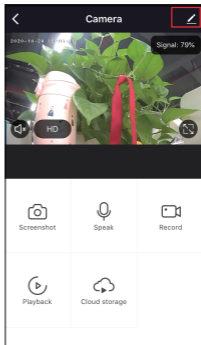
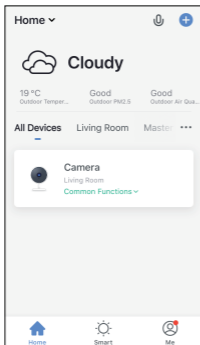

Q: In the network process, the process bar is always not 100%, add failure?

A: This camera only supports 2.4GHz WiFi router, please make sure you are using a 2.4GHz WiFi router. And confirm the WiFi password again.

Q: Repeated additions are failures?

A: After adding a failure, it is recommended to restart the device or power off, and then try to add again.

Q: The device cannot be previewed properly?

A: Check whether the network is normal, you can place the camera close to the router, and if not, it is recommended to reset the device and add it again.

Q: How to cut the camera network to another router?

A: First remove and reset the device on the App and then configure the device again by the App.

Q: Why I can't get the notifications with my cell phone App?

A: Please confirm that the App has been running on the phone, and the relevant reminder function has been opened; Message notification and authority confirmation in the mobile phone system have been opened.

Q: Why doesn't the device identify the SD card?

A: It is recommended to plug in SD card after power cut. Confirm whether the SD card is normally available and the format is FAT32. And the TF card can't be identified when the Internet environment is not good.



## Full-duplex audio

When the visitor push the doorbell button, you will get a call. You can see and hear the visitor in your App from the doorbell if you answer.

## Motion detection

Motion sensors will notify you when movement is detected.

## Shared device

The doorbell device can be shared with friends, and friends can also preview online. There is no limit to the number of sharing devices, but only 6 accounts are supported for online preview at the same time.

## Record

Record every moment using high capacity SD card storage.

## Day & Night

Powerful night vision means no interruptions, even in complete darkness.



Daytime



Night